

Hex Code Table		
✓ FMXXXX	Length (L)	
FM0830	1	
FM0831	2	
FM0832	3	
FM0833	4	
FM0834	5	
FM0835	6	
FM0836	7	
FM0837	8	
FM0838	9	
FM0839	10	
FM0840	11	
FM0841	12	
FM0842	13	
FM0843	14	
FM0844	15	
FM0845	16	
FM0846	17	
FM0847	18	
FM0848	19	
FM0849	20	
FM0850	21	
FM0851	22	
FM0852	23	
FM0853	24	
FM0854	25	
FM0855	26	
FM0856	27	
FM0857	28	
FM0858	29	
FM0859	30	
FM0860	31	
FM0861	32	
FM0862	33	
FM0863	34	
FM0864	35	
FM0865	36	
FM0866	37	
FM0867	38	
FM0868	39	
FM0869	40	
FM0870	41	
FM0871	42	
FM0872	43	
FM0873	44	
FM0874	45	
FM0875	46	
FM0876	47	
FM0877	48	
FM0878	49	
FM0879	50	
FM0880	51	

## Metric Spacers 19 mm

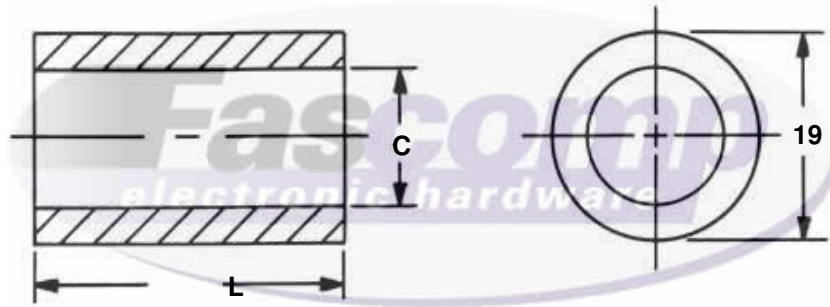

Create a part number:

Length	Clearance	Material	Finish
FMXXXX	XX	XX	XX
_____ . _____ . _____ . _____			

Hole Clearance Code (XX)			
✓	Code (XX)	Thread	C +0.3 -0.0
	4	M4	4.3
	5	M5	5.3
	6	M6	6.4
	8	M8	8.4
	10	M10	10.5
	12	M12	13
	14	M14	15

Material		
✓	Material Code (XX)	
	A	Aluminum
	B	Brass
	S	Steel
	SS	Stainless Steel
	N	Nylon

**Tolerances  
Unless otherwise Specified**  
 .xxx +/- .13mm  
 .xx +/- .26mm  
 Angular +/- 1 Degree  
 Linear +/- .13mm  
**Break all sharp edges**



✓	Compatible Finish	
	A, B, S, SS	0 - Plain
	B, S	5 - Nickel Plate (QQ-N-290)
	A	6 - Iridite #14 Gold (MIL-C-5541E)
	A	7 - Iridite Clear (MIL-C-5541E)
	A	9 - Alodine 1200
	B, S	12 - Zinc Clear (ASTM-B-633)
	B, S	16 - Electro Tin (MIL-T-10727 TYPE 1)
	SS	20 - Passivation (MIL-F-14072D)
	A	22 - Clear Anodize (MIL-A-8625-TYPE2) (Sulphuric) Hot Water Seal (Clear)
	A	24 - Black Anodize (MIL-A-8625)
	B, S, SS	26 - Black Oxide
	B, S	28 - Zinc Yellow (ASTM-B-633)

Source Control Drawing:  
To be produced by  
Fascomp Electronic Hardware

This document is the property of Fascomp Inc. and shall not be reproduced, distributed, or used as a basis for manufacturing without written permission from Fascomp Inc.